

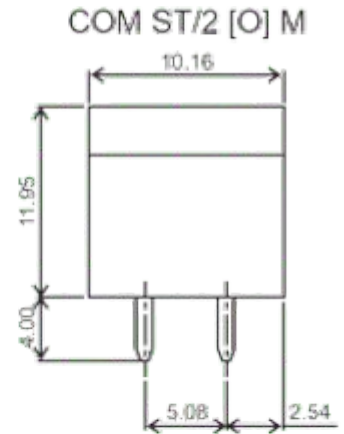

Manufacturer of PCB Terminal Blocks, Fuse Holders, Barrier Terminals, & Switches

*Screw Type (Cage-Clamp Pluggable Design) Connectors*

**Series COM ST M**

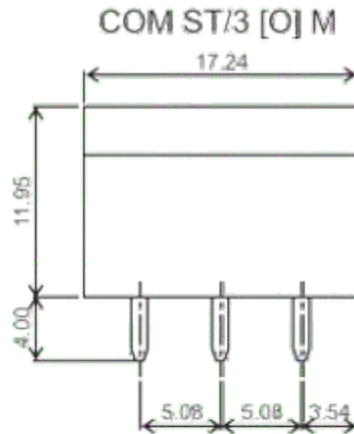
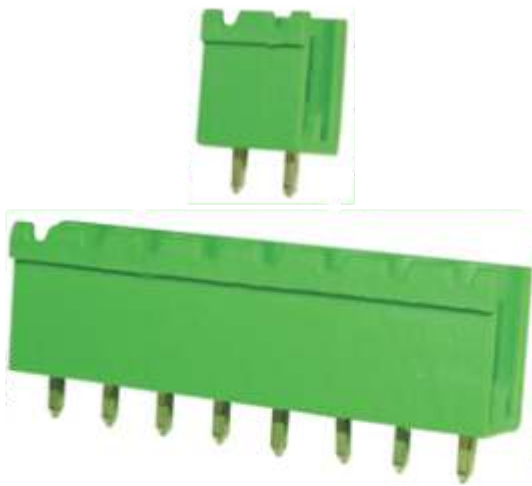

[O] Open Type (Without Side Walls)

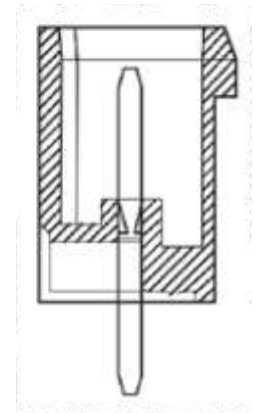
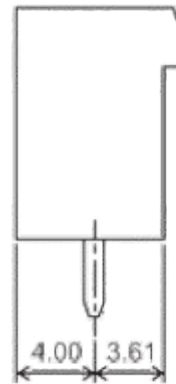

**TECHNICAL SPECIFICATIONS :**

Pitch	: 5.08 mm
Nominal Rating	: 15A/300V
Dielectric Strength	: > 2kV
Moulded Material	: PA66 - UL94 V0 or V2
Insulation Resistance	: > 1000 M Ω @ 500 Vdc
Terminal	: Tin Plated Copper Alloy

**ORDERING CODE**

Series	Poles	Grade
--------	-------	-------

→ COM ST/n [O] M P ←

n = Number of poles : 2 To 8  
Grade : P or C

P = Professional Grade  
C = Economy Grade

**Approval Data**

UL : 300V / 12A / 28-12 AWG  
cUL : 300V / 12A / 28-12 AWG  
CE : 300V / 15A / 28-12 AWG

